



5 ft. TUFF BLIND TOWER ASSEMBLY INSTRUCTIONS

TOOLS REQUIRED: 2 - 1/2" Open end box wrenches

PACKAGE CONTAINS:

- 4 - 1 1/2" x 5' Legs
- 4 - 1" x 5' Lower Braces (1 w/ Holes)
- 4 - 43" Top Braces
- 2 - 5' Upper ladder braces
- 2 - 1" x 5' Ladder Side Rails
- 5 - 17" Ladder Rungs
- 2 - 17" Ladder Braces
- 4 - 1" x 5' Cross Supports
- 4 - Plastic Foot Pads
- 1 - Earth Anchor & Turnbuckle
- 1 - Chain w/Cables & S-hooks

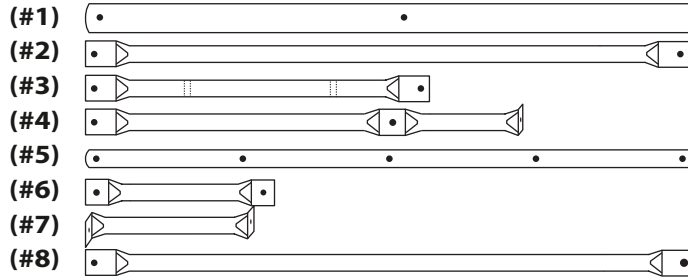

Hardware:

- 24 - 5/16" x 1.75" Bolts
- 20 - 5/16" x 2.5" Bolts
- 44 - 5/16" Nuts
- 4 - Fender Washers

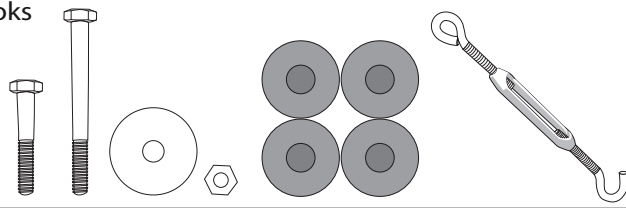

Assemble two sides of the tower:

- Lay down 2 legs(#1) with the holes facing up.
- Set the top(#3) and lower(#2) braces onto the legs forming a large Letter A
- NOTE: Do not use the lower brace with the holes drilled in the center!**
- Attach the cross support (#8) (oriented from the top left to the lower right) to the braces and the legs with the 2.5" bolts. (fig 1)
- Repeat for other tower side.

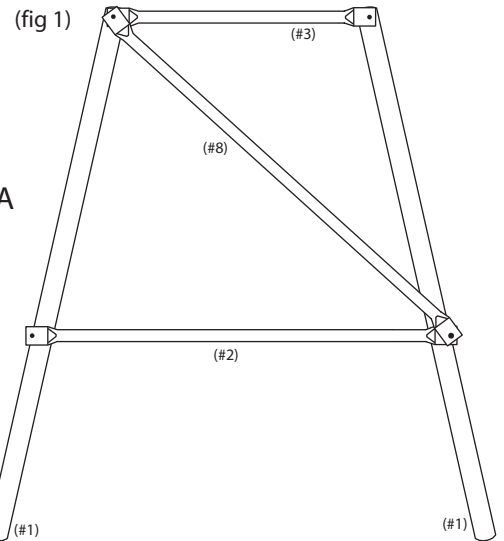

Assemble the front and back of the tower:

- Flip one of the sides over so the braces are facing down.
- Attach the lower braces (#2) and upper braces (#3) vertically onto each of the legs. (fig 2)
- NOTE: The lower brace with the holes in the center can now be used and will become the front of the tower.**
- Roll the entire tower so that the lower brace with the holes is facing up.
- Attach the second side to the upper and lower braces.
- (be sure the braces already mounted to the side remain facing outward) (fig 3)
- Attach the remaining cross supports(#8) to the front and back.

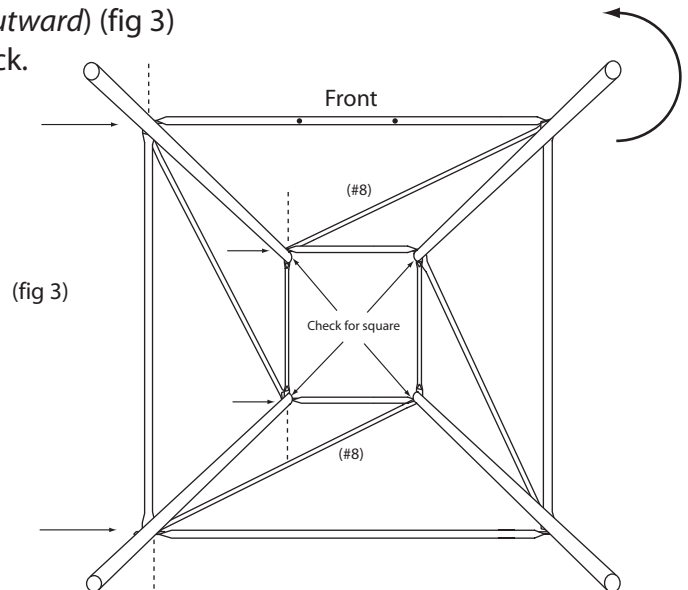
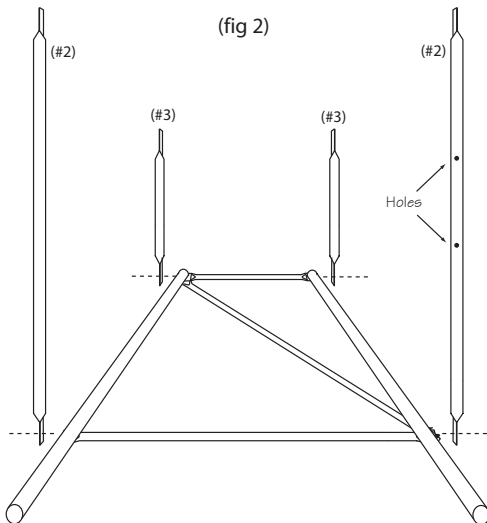

Check the stand for square by ensuring the distance diagonally corner to corner on the top braces is equal (also ensure the diagonal corner to corner distance between the legs is equal) (Fig3)

Assemble the ladder:

- Lay out the 2 ladder side rails (#5) with the holes facing up..
- Attach the 5 ladder rungs. (#6) Leaving the washers and nuts off the the top rung and 3rd rung from the bottom of the ladder.
- Flip the ladder over
- Attach the 2 lower ladder braces (#7) to the protruding bolts at the back of the 3rd rung ensuring the flat is pointing upwards.
- Attach the 2 upper ladder braces (#4) with the flat mounting tabs over the top rung. (fig 4)
- Attach the ladder assembly to the holes in the top(#3) and lower(#3) braces. (fig 5)
- Stand upright and install the plastic foot pads to the ends of the legs if needed (*use for soft, wet or unstable ground*)

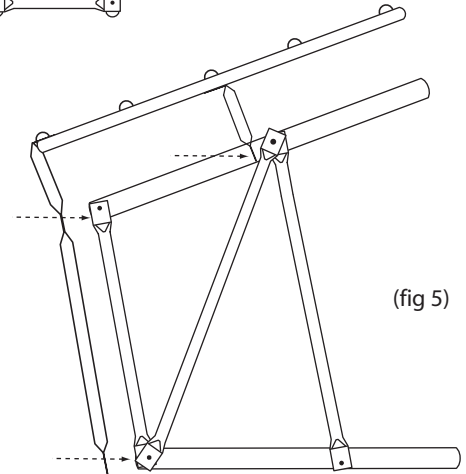
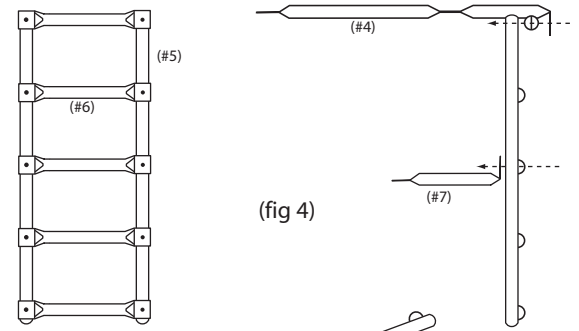

Attach Hold Down:

- Hang the S-Hooks attached to the cables over the open top end of the legs. (fig 6)
- Twist the auger screw completely into the ground centered between the four legs of the stand.
- Hook the end of the turnbuckle to one of the chain links attached to the auger screw handle ensuring that all of the slack is taken out of the cables.
- Twist the turnbuckle to take out the remaining slack in the cables. If you run out of adjustment and there is still slack in the cables, loosen the turnbuckle and

move the hook a couple of links closer to the auger. Re-tighten the turnbuckle and check the cable tension.

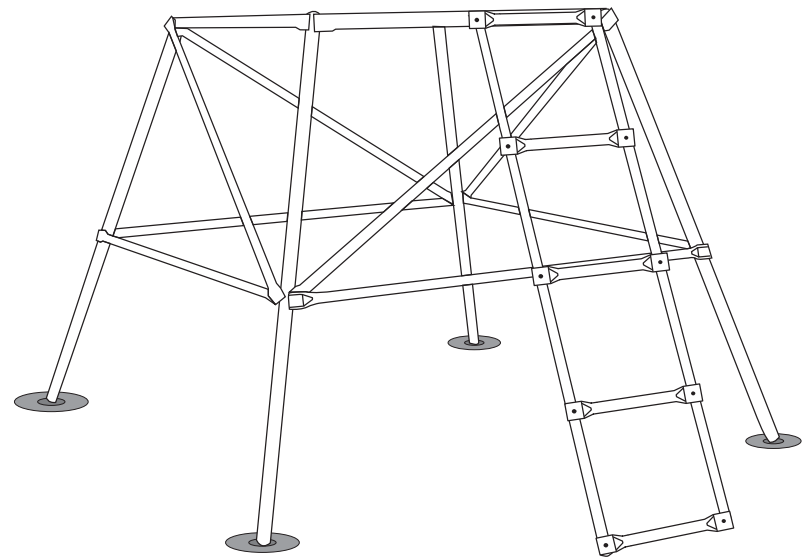
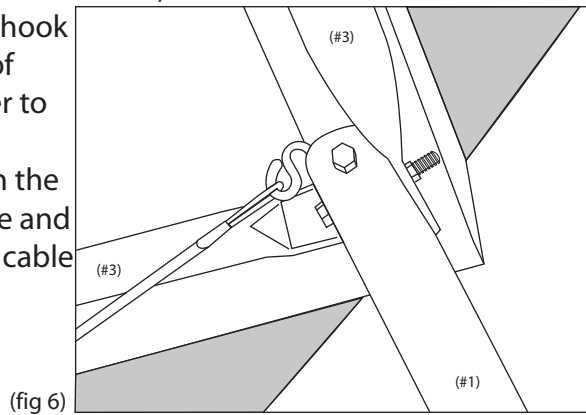

Attach the Blind to the Stand:

- The Tuff Blind Tower is pre-drilled in the bottom of each of the upper side braces (#3). Using these pre-drilled holes as a guide, drill up through the wooden floor of the Tuff Blind. From the inside of the blind drop a 2 1/2" bolt through each of the 4 drilled holes. Secure and tighten with supplied washers and nuts. (Fig 7)

